







## Recommended for AF and GN containers

- Available in 3 versions:
  1. with chrome plated steel handle and castors in galvanized steel
  2. with handle and castors in stainless steel
  3. without handle
- It allows to move without effort up to three stacked containers.
- Lightweight and easily manoeuvrable, thanks to its convenient handle
- Large capacity: can carry up to 150Kg in weight.
- Shockproof structure.
- It does not damage furniture or walls in case of accidental contact.
- Free of sharp corners for staff safety.
- Designed to be long lasting: performance remains basically unaltered when reused.
- Fully recyclable at the end of the operating life.

## MANUFACTURING MATERIALS

<b>Polyethylene</b>	trolley body; food contact safe	<b>Polyurethane</b>	insulating material between the walls of the body, free of CFC and HCFC
<b>Stainless steel/ Chrome plated steel</b>	handle	<b>Non-marking rubber</b>	castors

## CHARACTERISTICS

	<p>AF and GN containers housed in the recess of the body during handling.</p>		<p>Castors with diameter of 100 mm, in non-marking rubber and PP core, 2 fixed and 2 swivel.</p>
	<p>Monolithic structure, no sharp corners, junctions and welds.</p>		<p>Body filled with CFC and HCFC-free polyurethane foam.</p>
	<p>Trolley guaranteed for use: <b>-30° to +85°C.</b></p>		

## TECHNICAL SPECIFICATIONS

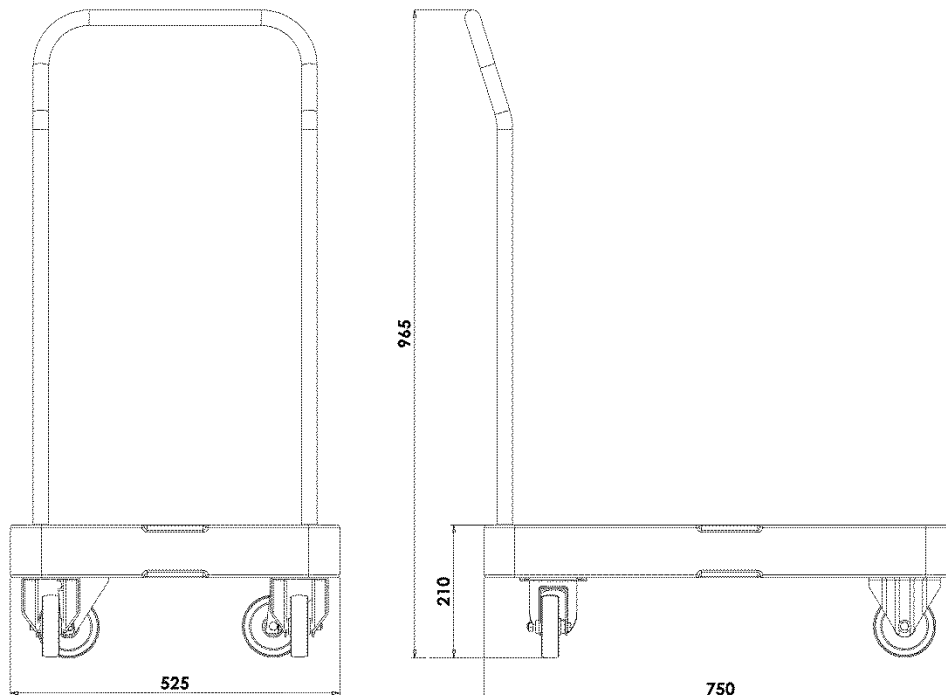

Model	Code	Colour	External dim. (mm)	Internal dim. (mm)	Capacity l	Weight Kg
Maxidolly trolley <b>chrome handle</b>	MAXI0012	grey/blue melange	525x750xh965			9.4
Maxidolly trolley <b>stainless steel handle</b>	MAXI0011	grey/blue melange	525x750xh965			9.4
Maxidolly trolley <b>without handle</b>	MAXI9002	grey/blue melange	525x750xh210			7



Via Savigliano 34 - 12030 Monasterolo di Savigliano (CN)  
 Tel. +39 0172812600 - Fax +39 017285991 - info@melform.com  
 GPS: Lat 44.681363 - Long 7.624809  
[www.melform.com](http://www.melform.com)